

# ST-YP series

RATIO : 2.3.4.5 (單段 1-Stage)

雙入力軸心 - 螺桿式

Double Input Shaft - Ball Screw

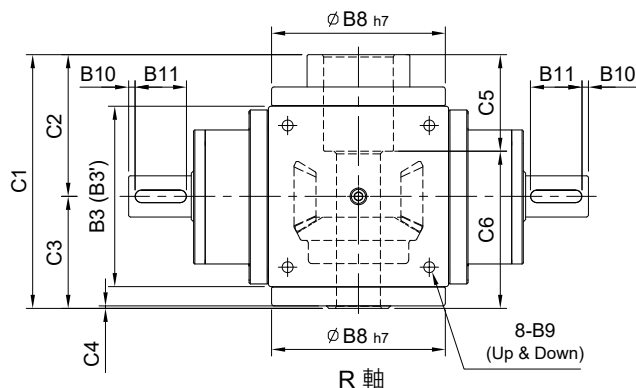
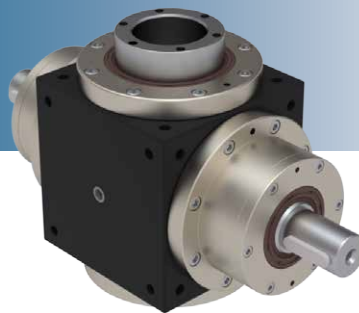

R 軸  
Shaft Direction  
B1

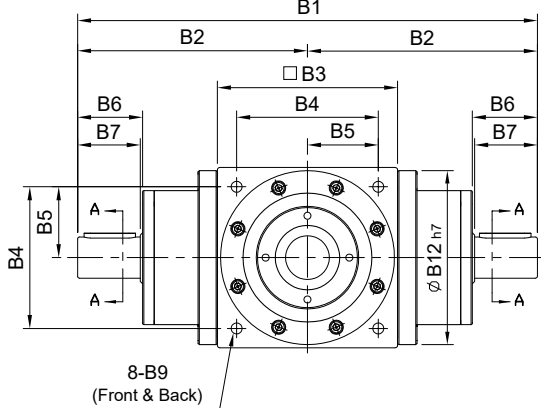

8-B9  
(Front & Back)

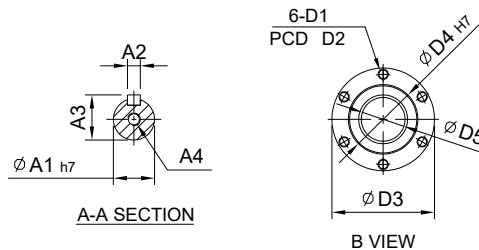

A-A SECTION

B VIEW

unit: mm

Model Code	75	90	110	140	170	210	240	
A	A1	16	18	22	32	40	55	
	A2	5	6	6	10	12	16	
	A3	18	20.5	24.5	35	43	59	
	A4	M5 x P0.8	M8 x P1.25	M8 x P1.25	M10 x P1.5	M12 x P1.75	M12 x P1.75	M16 x P2.0
B	B1	210	247	304	360	430	540	620
	B2	105	123.5	152	180	215	270	310
	B3(B3')	75(74)	90	110	140	170(168)	210	240
	B4	60	72	88	110	134	170	190
	B5	30	36	44	55	67	85	95
	B6	32	38	43	53.5	64	77	82
	B7	30	35	40	50	60	75	80
	B8	73	88	106	135	164	205	228
	B9	M6 x P1.0	M6 x P1.0	M8 x P1.25	M10 x P1.5	M12 x P1.75	M16 x P2.0	M16 x P2.0
	B10	2.5	5	5	5	5	5	5
	B11	25	25	30	40	50	65	70
	B12	73	88	106	135	164	205	228
C	C1	106	127	156	197	223	267	309
	C2	57	68	84	109	121	142	162.5
	C3	49	59	72	88	102	125	146.5
	C4	1.25	2	2	2	2.25	2.25	2.5
	C5	33	44	55	75	72	82	92
	C6	73	83	101	122	153	185	217
D	D1	M4 x P0.7	M5 x P0.8	M5 x P0.8	M8 x P1.25	M10 x P1.5	M10 x P1.5	M12 x P1.75
	D2	36	40	45	70	77	84	97
	D3	41.5	46.5	57.5	79.5	89.5	99.5	117.5
	D4	26	30	36	54	58	64	75
	D5	15	18	22	34	38	42	54
Weight ±3% (kg)	3.6	6.2	11.5	18	28	57		